

39

Sleazier

Puzzle Solution:

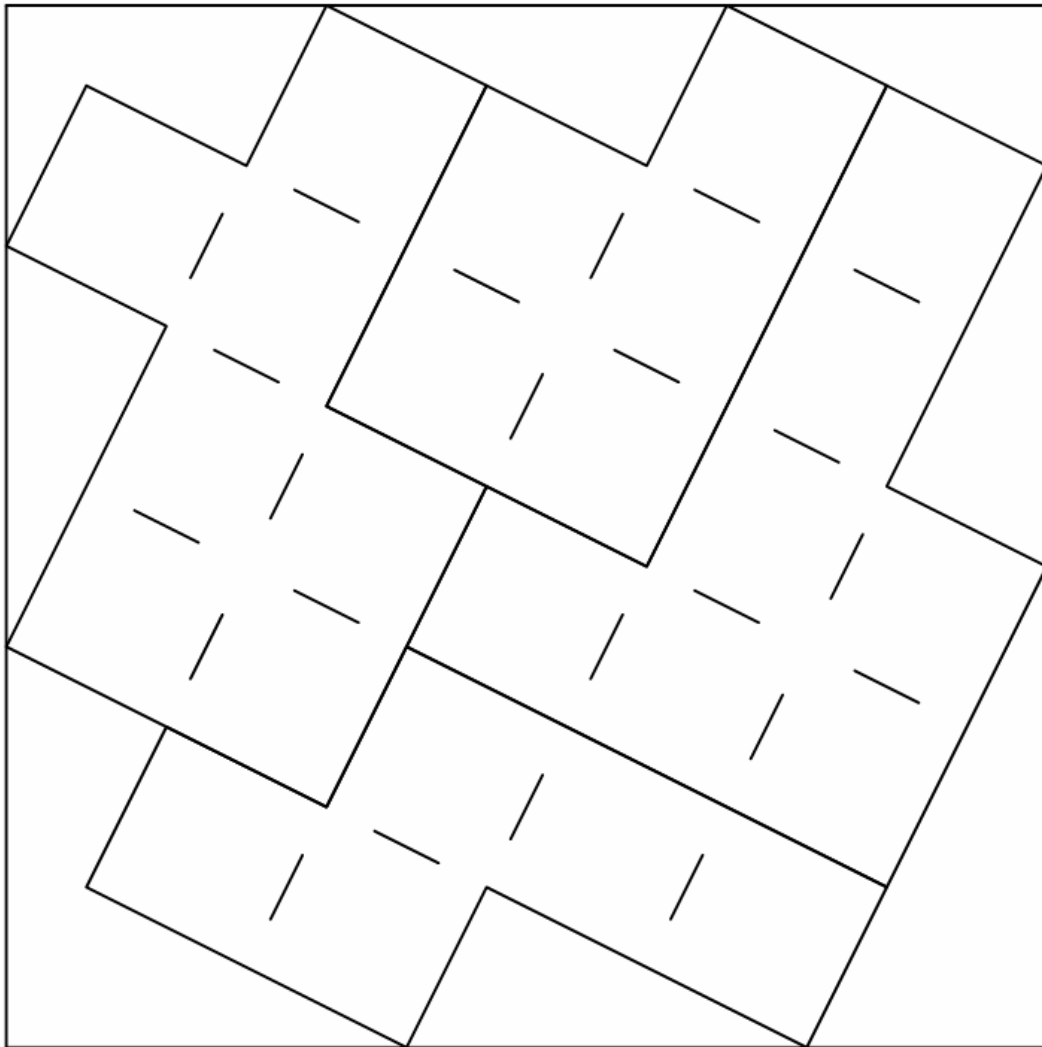

40

Homage to the Cube

Puzzle Solution:

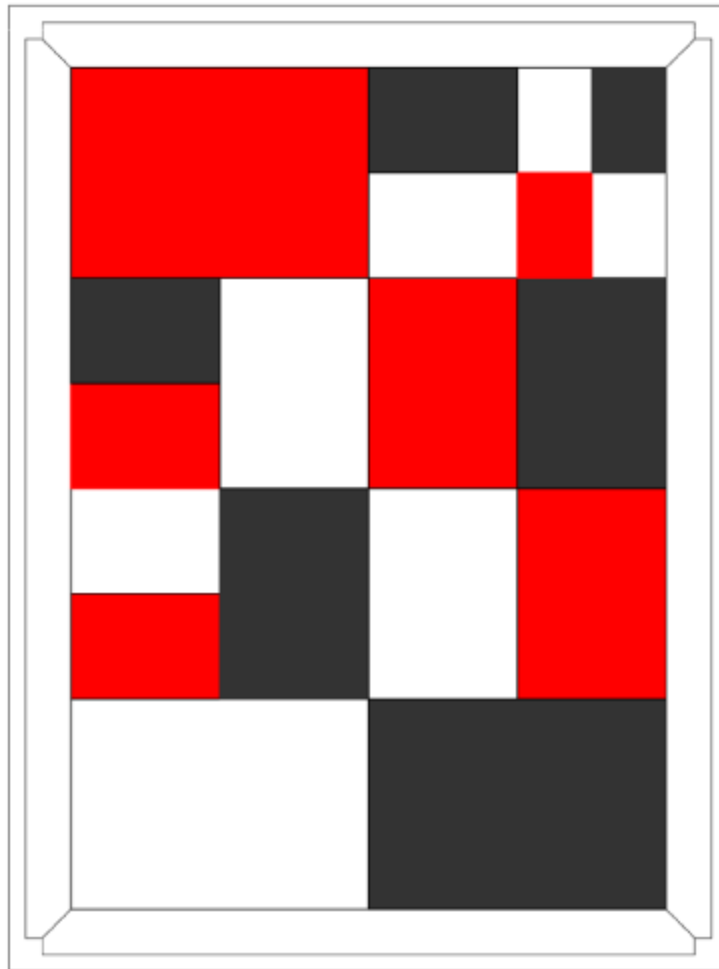

41

The Box of ZN

Puzzle Solution:

N/A



42

Solitary Confinement

Puzzle Solution:

N/A



43

The Skeleton Key

Puzzle Solution:

N/A



Stickman No. 5

Puzzle Solution:

Manipulate bloodwood tabs so that top and bottom panels are no longer hindered. Through sequential movements, manipulate the sliding side components until the bottom panel is free to move. Move the bottom panel until it stops. Manipulate the sliding side components again until the top of the box opens half way.

With the box now open, additional moves of the side components will allow a retaining bar to be slid out, causing the box to come apart into 78 individual pieces.

It is strongly recommended that the reciprocal pieces from separate panels do not get mixed together, and that you disassemble only one panel at a time.



Stickman No. 7

Puzzle Solution:

The puzzle is solved by sliding its drawers in various directions while manipulating the pull tabs that restrict their movement. This process is repeated until drawers are lined up with the maze exit slots found at one end. All four drawers have the same maze patterns in an identical order, so hidden maze patterns can be determined by examining the maze patterns exposed. It is beneficial to focus on freeing only one drawer at a time.



Gyro Brain

Puzzle Solution:

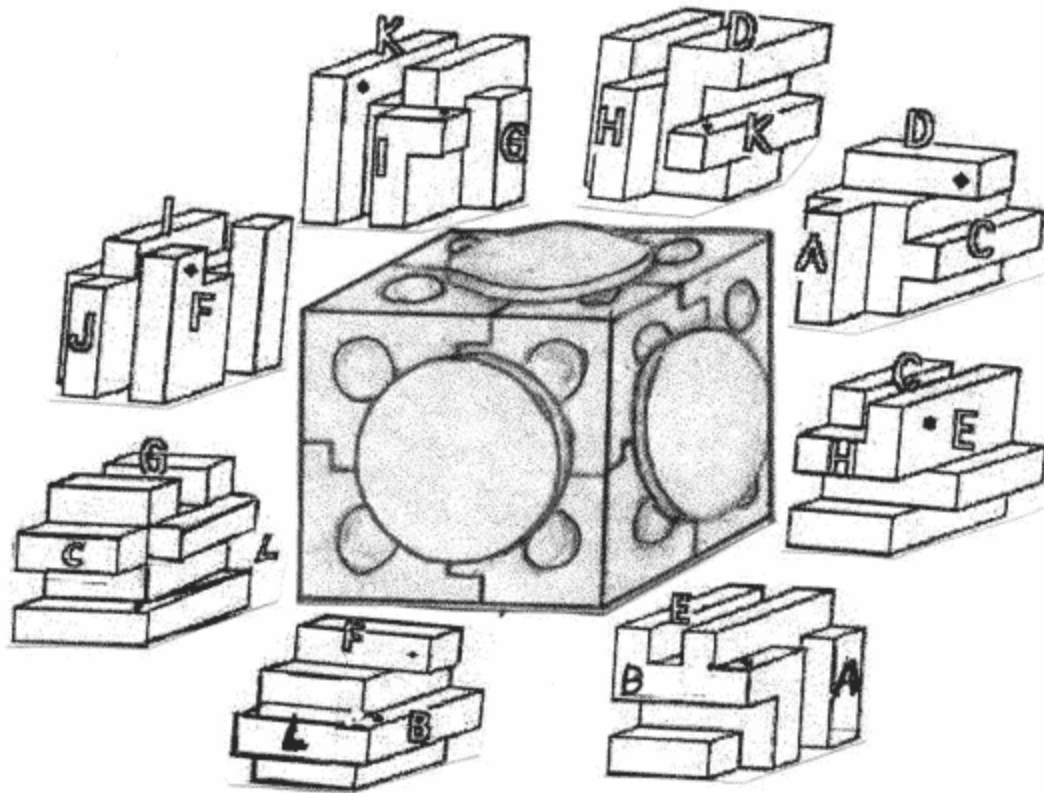

Bricks Thru Window

Puzzle Solution:

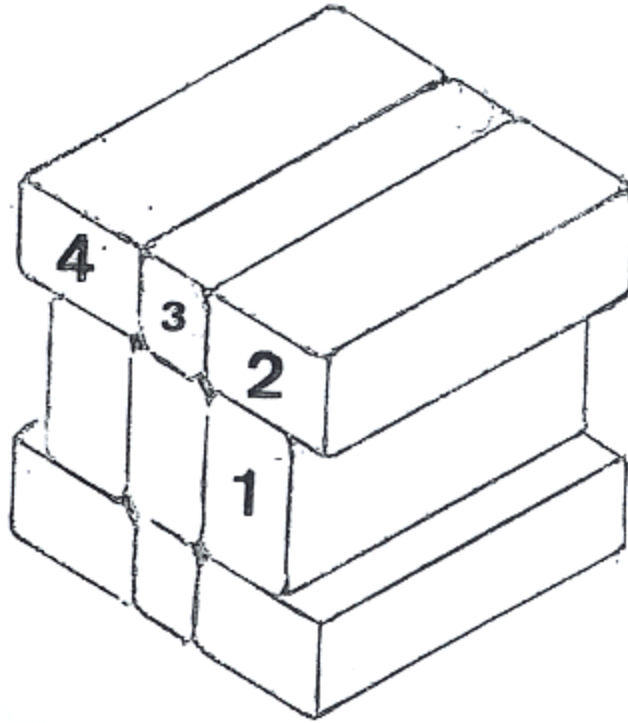

Note: there are 9 bricks, 7 are the same plus 2 narrow pieces. The puzzle should be placed with the narrow pieces at top and bottom.

In the middle there are 3 thick pieces.

Turn one outside piece 90 degrees (a quarter rotation). A thin cocktail stick can help with all the moves.

The brick above on top layer will drop down.

The top narrow brick can be levered out (again with cocktail stick).

The thick brick that dropped before can be rotated 90 degrees.

The other brick on top layer can now be pushed out of the box at an angle.

It is now easy to empty the box.

Replacing bricks is the reverse of the above moves.



Living Quarters

Puzzle Solution:

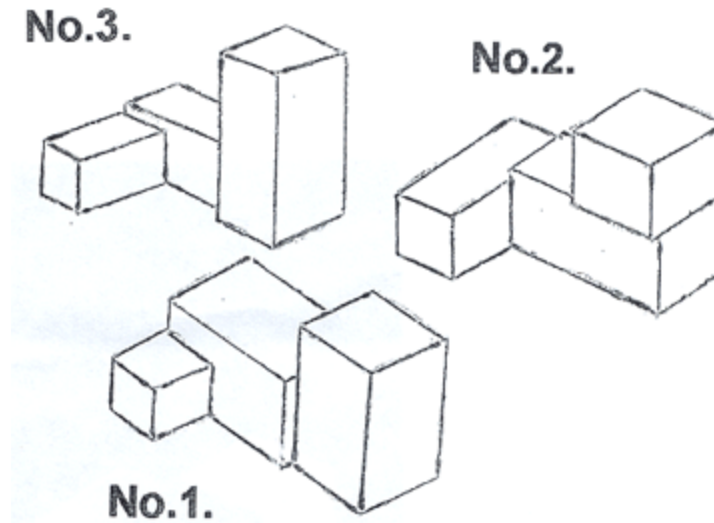

Note: puzzle consists of 4 quarters. One quarter has been placed and glued inside to help the solver!

Note the three pieces:

- 1) 1. thin, very thick, thick wood.
- 2) 2. medium, thick, very thick wood.
- 3) 3. thin, medium, thick wood.

Have the box facing you with glued piece at top left.

Place no.1 in box on left, thin block at top. (All pieces are placed at edge of box).

Pull no.1 out (2cm) till it hooks under glued piece.

No.2 is placed at lower right, very thick block at the top. Bottom block will hook under piece no.1.

Keep both no.1 and no.2 pulled out and hooked together (about 2 cm).

Piece 3 goes in at an angle, thin wood first into middle of box, hooking under no.1 and no.2.

Push the three pieces into box together.

To empty the pieces, reverse the above moves. Your little finger hooked into box or "emptying ketchup bottle technique" will be needed for first move.



Triple Trouble

Puzzle Solution:

The blocks cannot be inserted into the box as a unit, nor can they be inserted one-at-a-time. Block C (see figure) must be inserted half-way first. The other blocks remain together as they slide against C, and cover the distance to the base of the box at twice the speed. I recommend the following procedure.

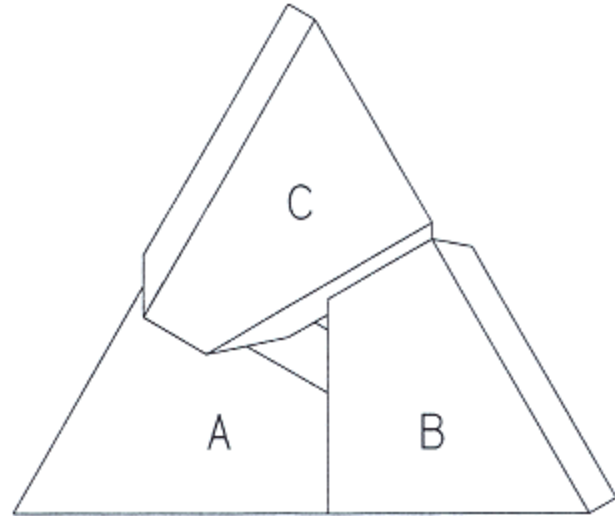

1. Identify the top face of each block. While the other faces are all asymmetrical, the top face of each is a symmetrical kite-shape with two opposed right angles, a 120° angle, and 60° angle.
2. Place all the blocks upside-down and arrange them in a circle, with the the 60° angles pointing outward.
3. Note that no two blocks are alike, so there are 2 possible arrangements: blocks A, B, and C might go around clockwise or counterclockwise. Only one is correct, so try fitting them together; if the contacting faces are not flush against each other, then swap any two blocks to correct the arrangement.
4. Now identify block C. Its bottom face (which is now facing up) is the most oblong of the three, and includes both the longest and shortest edge of all the bottom faces. (It is also the only block whose contact surfaces with the other blocks are both non-vertical.)
5. Turn the blocks right-side-up and hold them in the air. Hold A and B together with one hand, with C in the other. Now travel block C down along the sides of the other two blocks until its bottom protrudes beneath them by half its height. Seen from below, the arrangement will look like the figure.
6. Insert the bottom half of block C into the box, taking care not to let it drop in.
7. The next difficulty is to guide blocks A and B in. All the blocks should now slide in with little difficulty. If they jam, then one got a little ahead of the others. Gentle jiggling and/or lifting of a block are sufficient to correct this. Never apply downward force to a block, as this will cause it to jam.

Block Removal Hint

Removing the blocks is a matter of artful jiggling. Turn the box upside-down, just over a suitable surface for the blocks to fall onto, and jiggle. With the other hand, apply gentle pressure to the blocks from below. Without giving away too much information about the solution, I can only advise you to try placing a little extra pressure on particular blocks in a trial-and-error fashion. (It's easier than it sounds.)



Necklace Packing Puzzle

Puzzle Solution:

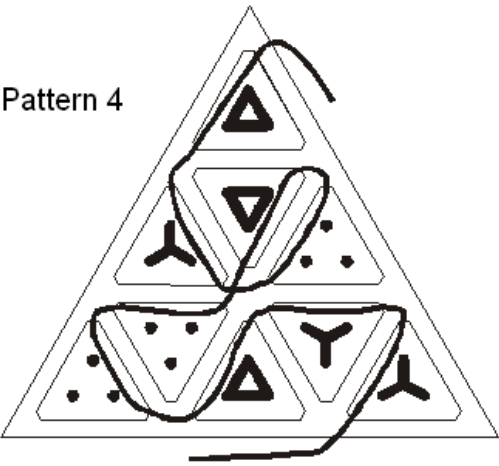
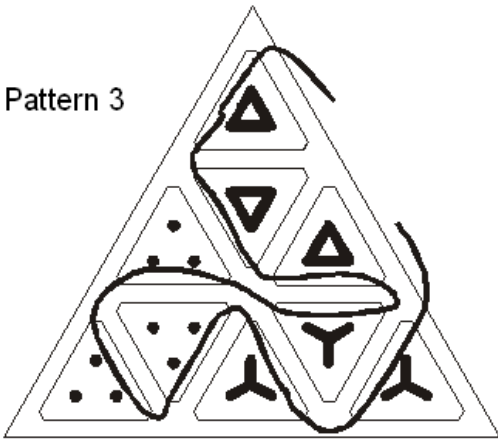
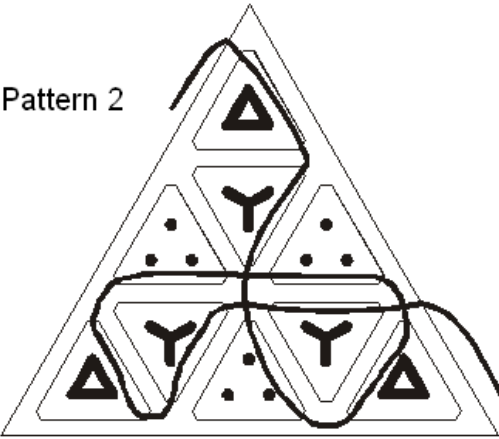
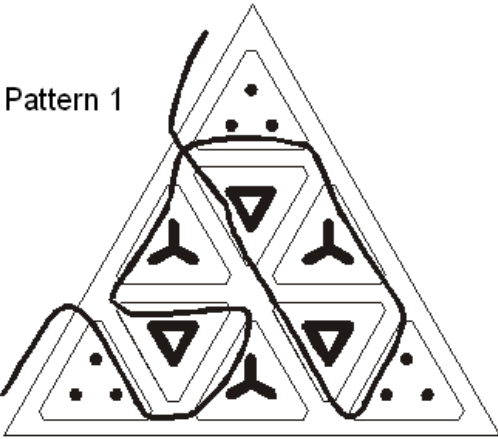

Butterfly

Puzzle Solution:

$\rightarrow 3 \quad 4 \uparrow 5 \uparrow 6 \rightarrow 1 \quad 4 \downarrow 5 \quad 1 \uparrow 4 \quad 5 \downarrow$
 $\uparrow 1 \quad 4 \uparrow 2 \quad 6 \downarrow 3 \downarrow 1 \rightarrow 4 \uparrow 3 \quad 4 \quad 5 \uparrow$
 $6 \uparrow 2 \rightarrow 3 \quad 4 \downarrow 1 \quad 6 \uparrow 2 \uparrow 3 \rightarrow 4 \downarrow 1 2 \uparrow 3$

 $6 \downarrow 3 \downarrow 1 \rightarrow 2 \rightarrow 5 \leftarrow 1 \quad 2 \uparrow 4 \uparrow 6 \leftarrow$

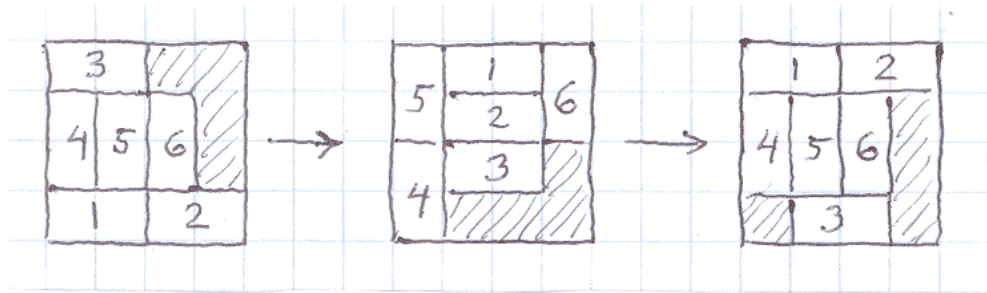
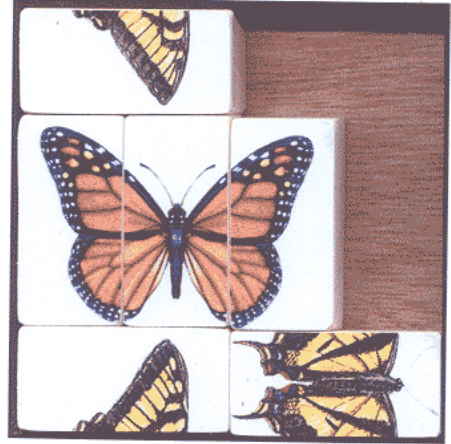

Puzzle Solution:

1. Slide a walnut plate
2. Twist the box like a Rubik's Cube (first diagram)
3. Slide and twist the box (second diagram)
4. You can now open all the lids

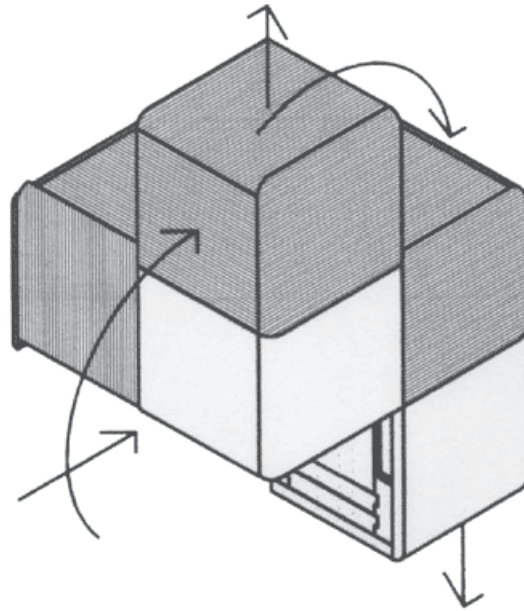
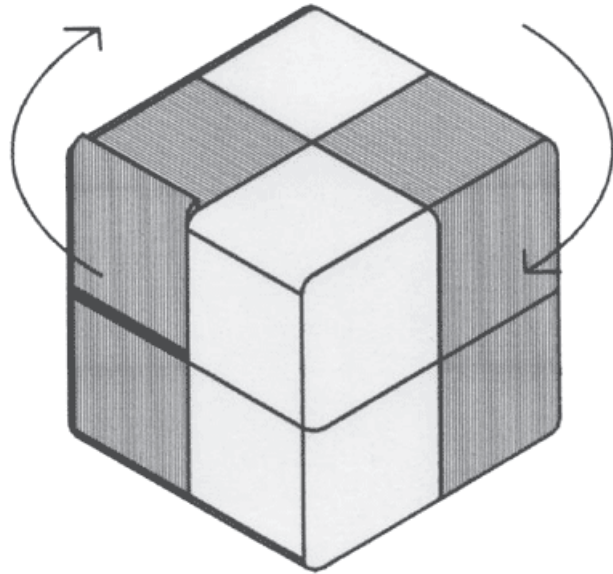

Petit Heart

Puzzle Solution:

1. Move box A about 1 cm to this side.
2. You can slide the box A's top plate, but don't remove the top plate yet; slide it only about 2 cm.
3. Slide box B's top plate and remove it.
4. Slide box A's top plate and remove it.

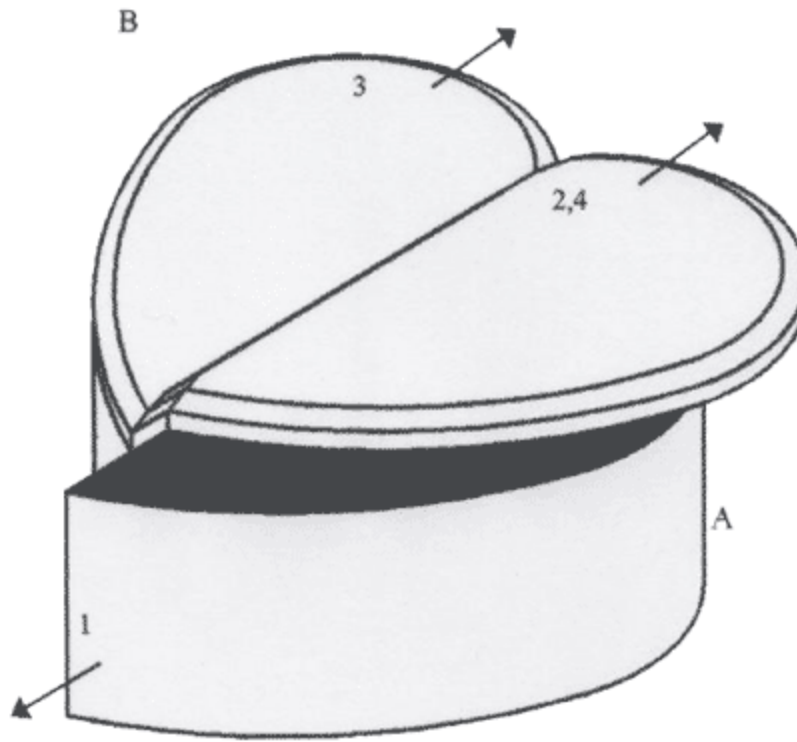

Caged Knot

Puzzle Solution:

XXXXX	X...X	XBBBX	X...X	XXXXX
X.C.X	..C..	...B.	..C..	X.C.X
X.C.X	DDDDD	DB.BD	DD..D	X.C.X
X.C.X	..C..	.BCB.	..C..	X.C.X
XXXXX	X...X	XBBBX	X...X	XXXXX

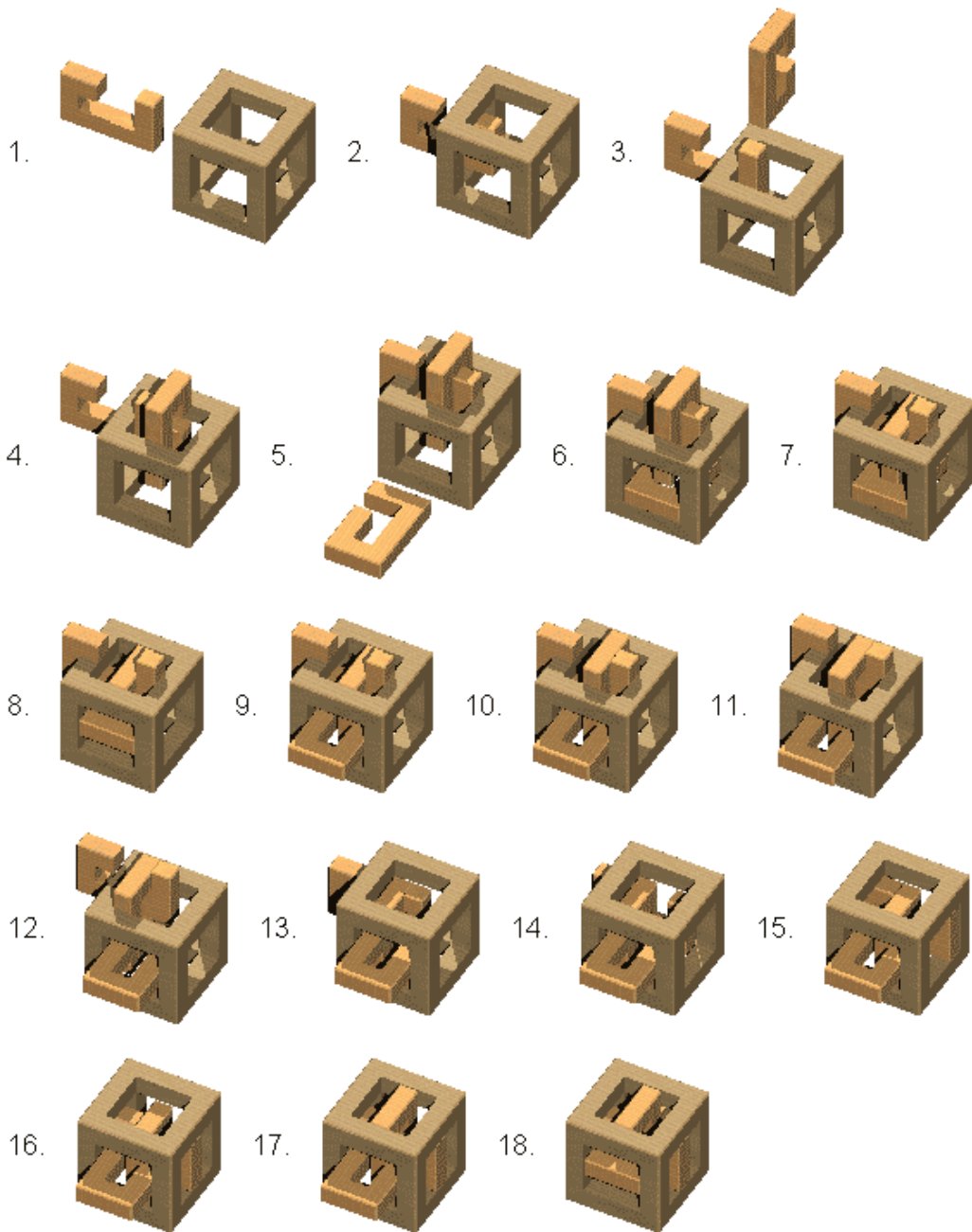

Icosahedron92

Puzzle Solution:

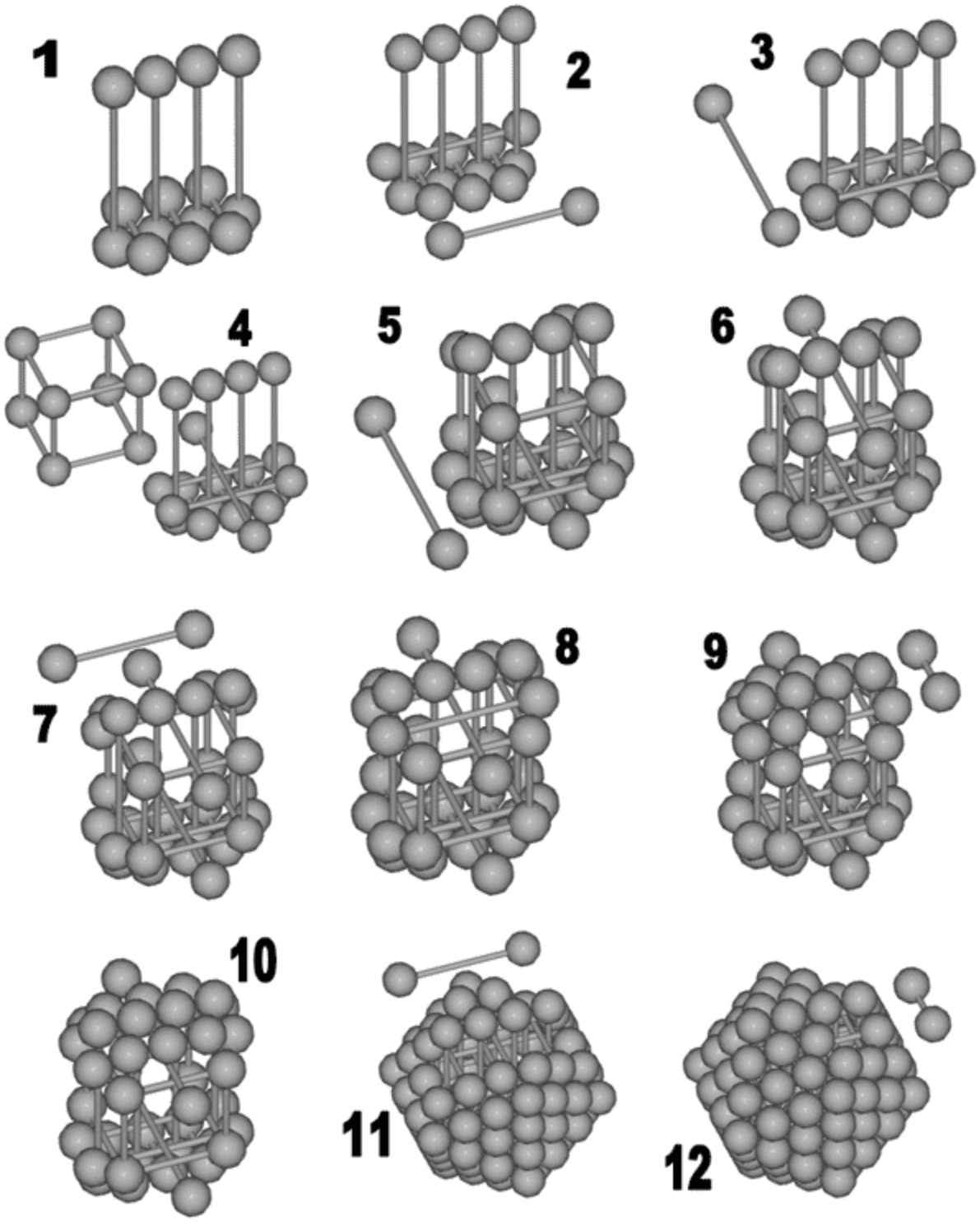

Swan

Puzzle Solution:

Every piece is numbered -- just follow the order of the numbers.

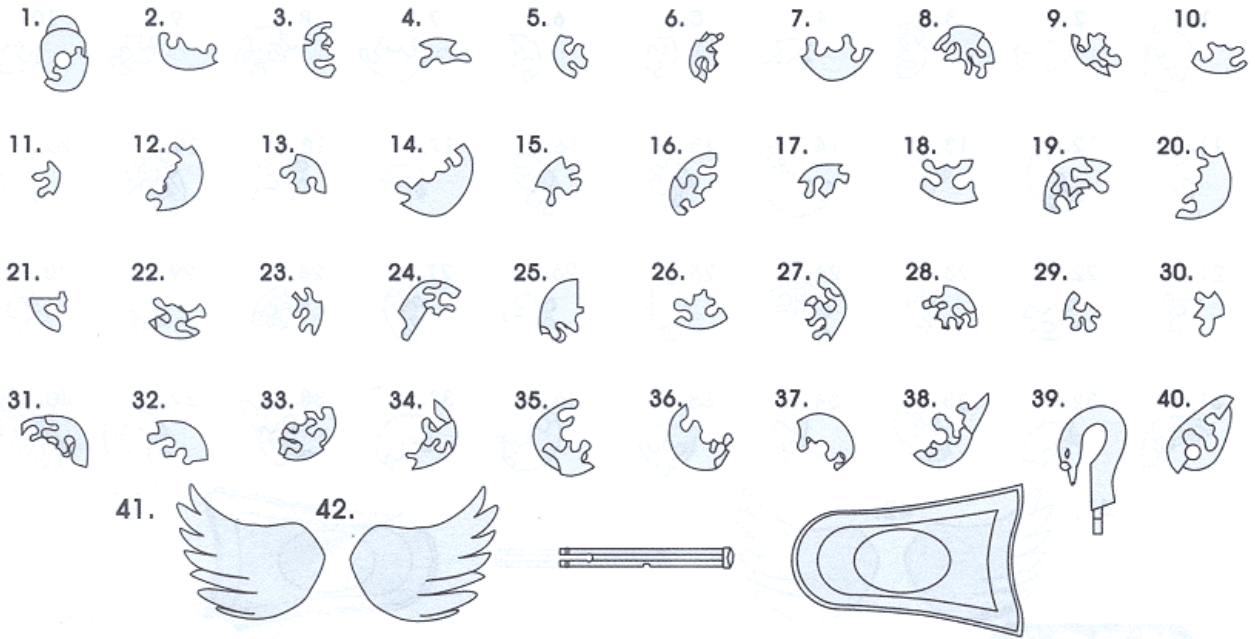

cuBBox

Puzzle Solution:

Spin it. That's all!

